

PRODUCT SPECIFICATIONS

The XRC33F16CD low cost, 3 Watt Ka-band VSAT Transceiver will operate with any industry standard VSAT modems.

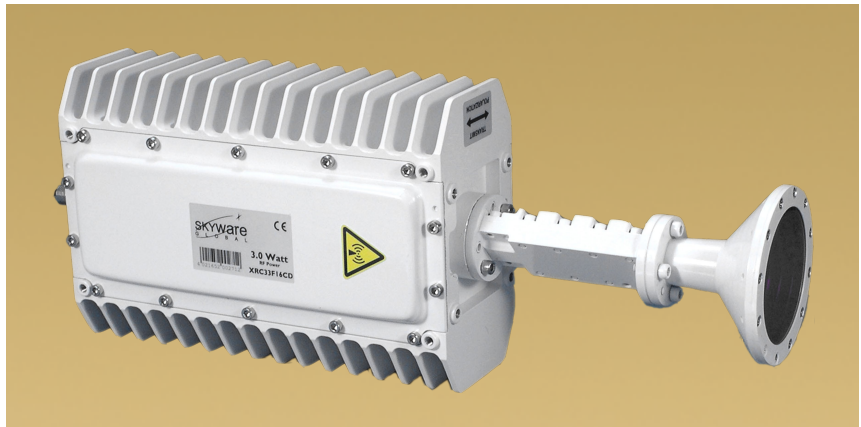

XRC33F16CD low cost, 3 Watt Ka-band VSAT Transceiver

Skyware Global introduces the world's first truly integrated Ka-band VSAT transceiver. This breakthrough product will lead the way for the next generation VSATs in Ka-band.

The XRC33F16CD will work with normal industry standard VSAT modems. It features excellent RF performance and very high reliability.

The product is built with a very compact housing for lowest cost and best antenna integration.

Circular Polarization is achieved by optimum matched feed chain components consisting of a field-adjustable Waveguide Polarizer and high efficiency Feed Horn.

- Meets EN 301 459 and FCC 47 CFR 15/25 AB with 50 dB (1.2 m aperture) antenna
- RoHS compliant
- Compatible with standard VSAT modems
- PLL LNB
- Fully integrated housing
- Fast and easy installation
- Integrated OMT and TRF for best EIRP and G/T
- Every unit is 100% tested over the

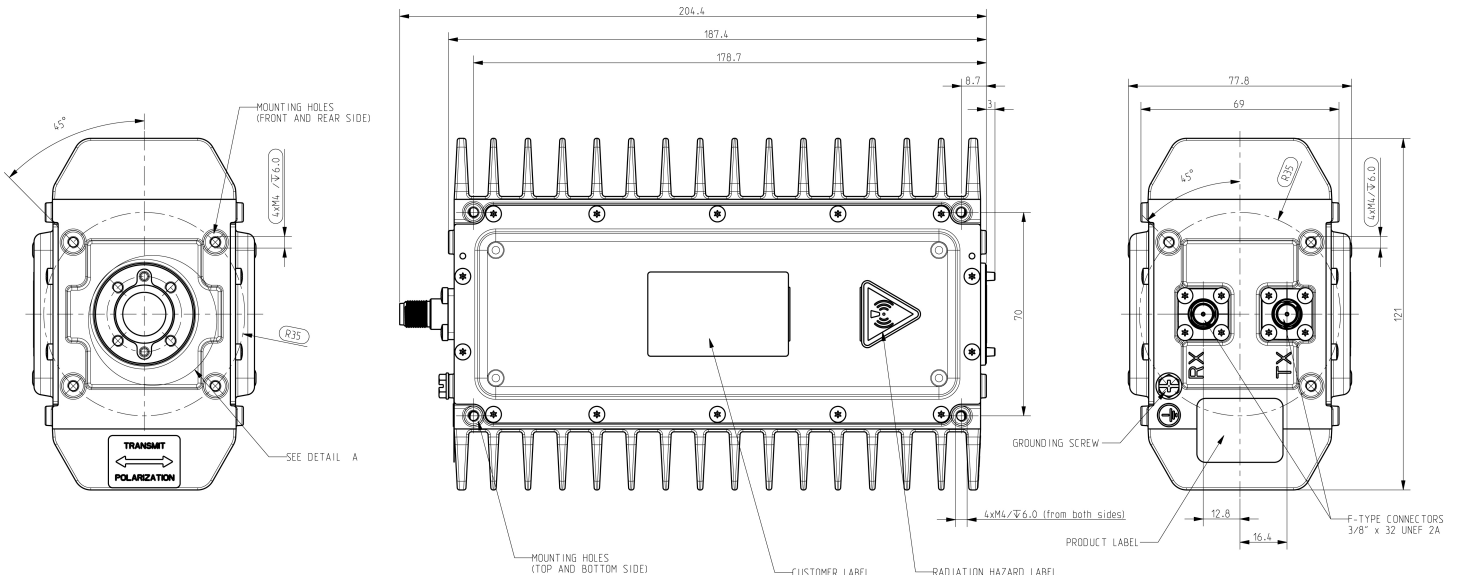

SPECIFICATIONS

XRC33F16CD low cost, 3 Watt Ka-band VSAT Transceiver

OMT

Parameter		Minimum	Typical	Maximum	Unit	Note
XPD on Common Port	TX	30	35		dB	
	RX	25				
Common Port Connector						11.3 mm circular-WG, non-grooved flange, hole pattern acc drawing

TX Sub-System (BUC)

Parameter		Minimum	Typical	Maximum	Unit	Note
IF Input Frequency Range		950		1450	MHz	
RF Output Frequency Range		29.5		30.0	GHz	
Local Oscillator Frequency (Nominal)			28.55		GHz	external 10 MHz Reference
Local Oscillator Integrated Phase Noise				2.4	"	DSB rms, 100 Hz – 100 kHz
Local Oscillator External Reference Frequency (Nominal)			10		MHz	
RF Output Power, P1dB			34.5		dBm	on OMT Common Port
Conversion Gain, Linear Operation		52	55	58	dB	Over frequency and operational conditions
IF Input Drive Power	Nominal Operation		-17		dBm	Application dependant
RF Output Spurious Level			according EN 301 459 and FCC 47 CFR 15/25 AB			with 50 dBi (1.2m aperture) antenna
IF input Impedance (Nominal)			75		Ohm	
IF Input Connector						F-type Receptacle
Supply Voltage		15		50	V	
Supply Current			1.0	1.3	A	24 V, Carrier On

RX Sub-System (LNB)

Parameter		Minimum	Typical	Maximum	Unit	Note
RF Input Frequency Range		19.2		20.2	GHz	
IF Output Frequency Range		950		1950	MHz	
Local Oscillator Frequency, Nominal			18.25		MHz	
Local Oscillator Frequency Tolerance				+/- 25	ppm	
Local Oscillator Integrated Phase Noise				2.0		100 Hz - 1 MHz
Noise Figure @ 25°C				1.5	dB	TX On (Carrier On or Off)
Conversion Gain		50	56	62	dB	
Image Band Rejection		30			dB	
IF Output IP3		+10			dBm	
IF Output Impedance			75		Ohm	
IF Output Connector						F-type Receptacle
Supply Current				200	mA	
Supply Voltage		9		25	V	

General Specifications

Parameter		Minimum	Typical	Maximum	Unit	Note
Weight			1800		g	Radio Module without Feed
Operating Temperature		-40		60	°C	
Moisture/Humidity Protection						IP67

